

105045LI

Gullies - concave grating D400



DESCRIPTION

Gullies for road infrastructure, industrial zones D400

ADVANTAGE PRODUCT

- Hinged grating (opening direction can be changed)
- Concave grating, with round bars
- Lateral outlet for DN 160 pipe.
- 2 handling hooks
- Grating supports on 6 points with EPDM seal.

MATERIAL

Ductile iron GJS 500-7 depending on EN1563

CERTIFICATION THIRD PARTY

Conform PTV 802, type I class D400
Certified EN124-2 BENOR by Copro

PLACE OF INSTALLATION

Group 3, →see EN124-1

For gully tops installed in the area of kerbside channels of roads which when measured from the kerb edge, extend a maximum of 0,5m into carriageway.

Confirmation about concave gratings:

EN124-2 is not applicable for concave gratings installed onto roads. These gratings need to be installed in areas of kerbside channels along roads

OPTION

Available with flat grating: 105045LP

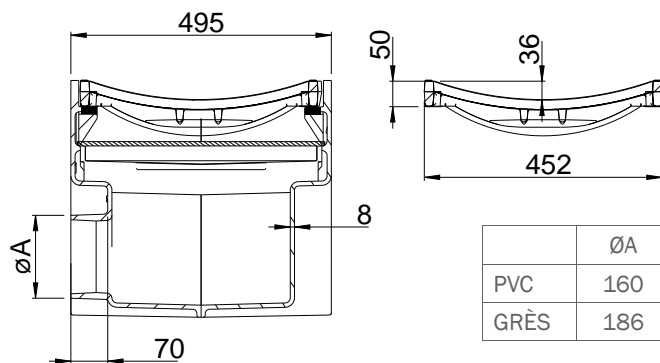
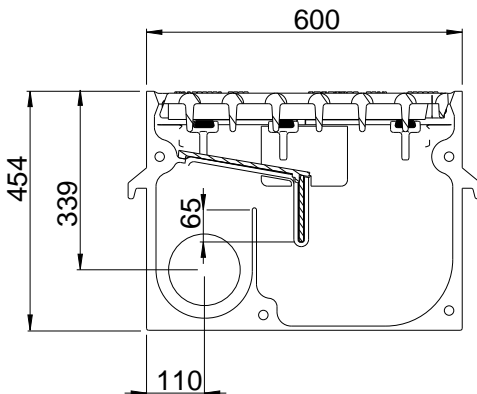
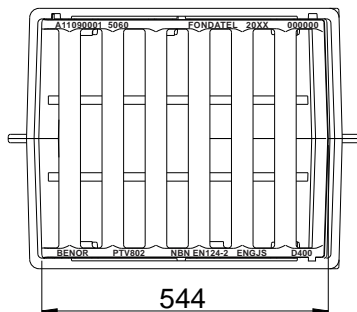

REFERENCE	ARTICLE N°	ARTICLE N° COPRO	KG	CAPACITY	CAPACITY HOLDING TANK
AVA 506045 concave - round bars - lateral outlet - pvc	105045LIO.160	0452/0275	141,0	10,44 dm ²	37,5L
AVA 506045 concave - round bars - lateral outlet - gres	105045LIO.GRES	0452/0295	141,0	10,44 dm ²	37,5L

Sizes in mm - Weights, sizes and sketch are indicative - Uncontrolled distribution.

105045LI

Gullies - concave grating D400

BENOR



hinged



<https://fondatel.com/index.php/environmental-policy-2/?lang=en>
<https://qr.co2logic.com/52518ea7746fcbcc911c6b2a8873e80>



BENOR



The validity of the data sheet can be checked using the device article n° COPRO on the COPRO website. <https://extranet.copro.eu/en/Sheets>

ENVIRONMENT

0 kg CO₂/product through compensation (*)

(*) Following our balance sheet of carbon dioxide emissions, Fondatel made an action plan to reduce its carbon dioxide emissions with 20% latest 2025 following European regulations.

In order to compensate actual balance of emissions which can't yet be avoided, Fondatel engaged itself to invest into certified climate projects, which themselves help to lower global carbon emissions and present multiple gains described in the list of Objectives of Sustainable Development by United Nations.

Compensation is 293,28 kg CO₂/product

CERTIFICATION THIRD PARTY

- Conform PTV 802, type I class D400
- Certified EN124-2 BENOR by Copro

OPTION

Marking/logo on request.

VARIANTS

Available with concave grating: 105045LI