

103040LI

Gullies - concave grating D400

PTV 802

hinged



DESCRIPTION

Gullies for road infrastructure, industrial zones D400

ADVANTAGE PRODUCT

- Hinged grating (opening direction can be changed)
- Concave grating, with round bars or 45° bars
- Lateral outlet Ø PVC 160
- 2 handling hooks
- Grating supports on 6 points with EPDM seal.

MATERIAL

Ductile iron GJS 500-7 depending on EN1563

PLACE OF INSTALLATION

Group 3, →see EN124-1

For gully tops installed in the area of kerbside channels of roads which when measured from the kerb edge, extend a maximum of 0,5m into carriageway.

Confirmation about concave gratings:

EN124-2 is not applicable for concave gratings installed onto roads. These gratings need to be installed in areas of kerbside channels along roads

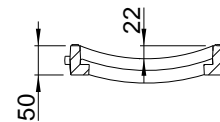
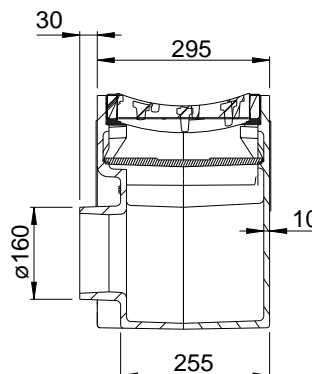
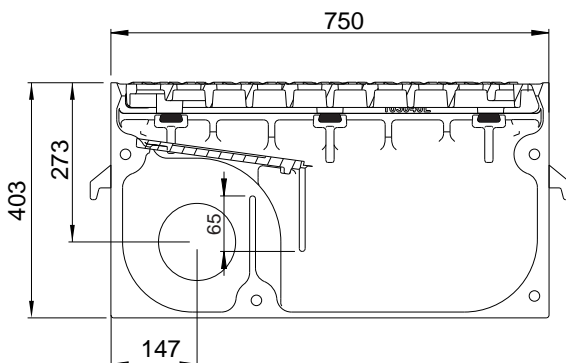
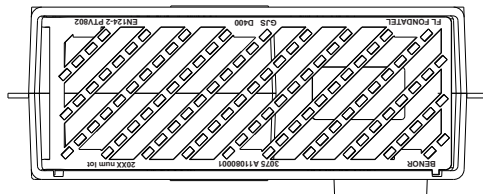
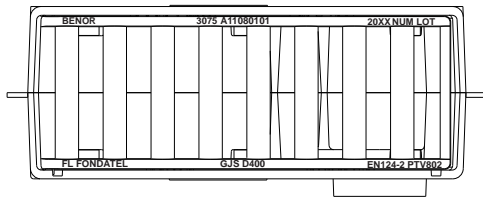

REFERENCE	ARTICLE N°	ARTICLE N° COPRO	KG	CAPACITY	CAPACITY HOLDING TANK	PACK.
AVA 307540 concave - round bars - lateral outlet - pvc	103040LI0.160	0452/0333	121	9,10 dm ²	24,7L	12
AVA 307540 concave - 45° bars - lateral outlet - pvc	103040LI7.160		121	9,56 dm ²	24,7L	12

Sizes in mm - Weights, sizes and sketch are indicative - Uncontrolled distribution.

103040LI

Gullies - concave grating D400

PTV 802



hinged



<https://fondatel.com/index.php/environmental-policy-2/?lang=en>
<https://qr.co2logic.com/52518ea7746fcbcc911c6b2a8873e80>



The validity of the data sheet can be checked using the device article n° COPRO on the COPRO website. <https://extranet.copro.eu/en/Sheets>

ENVIRONMENT

0 kg CO₂/product through compensation (*)

(*) Following our balance sheet of carbon dioxide emissions, Fondatel made an action plan to reduce its carbon dioxide emissions with 20% latest 2025 following European regulations.

In order to compensate actual balance of emissions which can't yet be avoided, Fondatel engaged itself to invest into certified climate projects, which themselves help to lower global carbon emissions and present multiple gains described in the list of Objectives of Sustainable Development by United Nations.

Compensation is 251,68 kg CO₂/product

CERTIFICATION THIRD PARTY

- Conform PTV 802, type F1 class D400
- Certified EN124-2 BENOR by Copro

VARIANT

Available with flatgrating: 103040LP

VARIANT



Sizes in mm - Weights, sizes and sketch are indicative - Uncontrolled distribution.